



Refrigerator
Refrigerator
Code: 2039 000

Product Details

Product type	Single door built-in freezer
Energy class	A+
Total gross capacity	235 Lt
Freezer net Capacity	212 Lt
Control type	Electronic control with LED display
Alarms	Doppio allarme: porta aperta/temperatura
Door	Reversible door - standard hinges on the right
Hinges	Slide-type
Lighting	LED lighting
Dimensions	540x1755x560 mm
Climate class	SN/T (tropical +10°C/+43°C)
Annual energy consumption	277 kWh
Freezing capability	10 Kg / 24h
Noise level	39 dB(A)
Power Supply	220-230V - 50Hz
Optional accessories	<i>Kit for side by side installation</i>

Features



Advanced fast freeze



No-frost freezer

Dimensions

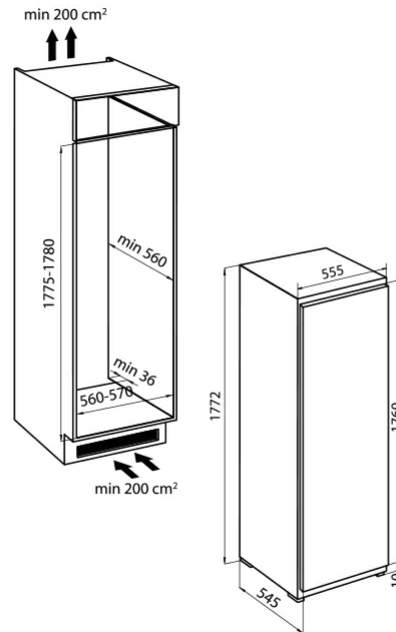

Optional accessories



kit for side by side installation 2038 039

06-08-2019 11:13:01