



Refrigerator  
Refrigerator  
Code: 2038 000

## Product Details

Product type	Combined built-in refrigerator
Energy class	A++
Total gross capacity	305 Lt
Refrigerator net capacity	301 Lt
Control type	Electronic control with LED display
Alarms	Doppio allarme: porta aperta/temperatura
Door	Reversible door - standard hinges on the right
Hinges	Slide-type
Lighting	LED lighting
Dimensions	540x1755x560 mm
Climate class	SN/T (tropical +10°C/+43°C)
Annual energy consumption	113 kWh
Noise level	37 dB(A)
Power Supply	220-230V - 50Hz
Optional accessories	<i>Kit for side by side installation</i>

## Features



Personal system



Ventilated refrigerator



Fresh zone



Humidity control



Advanced fast freeze

## Dimensions

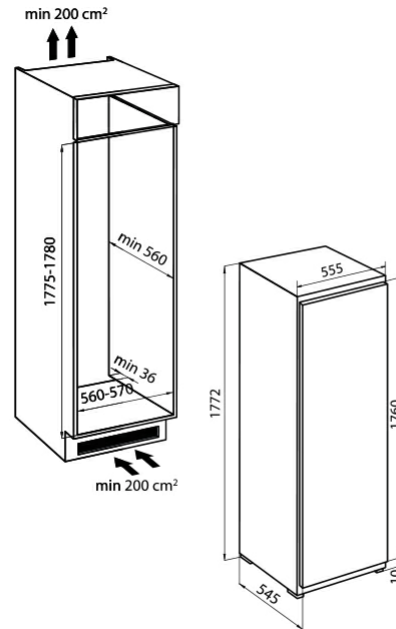

Optional accessories



kit for side by side installation 2038 039

06-08-2019 14:12:39