

Cooker hob Milanello Copper

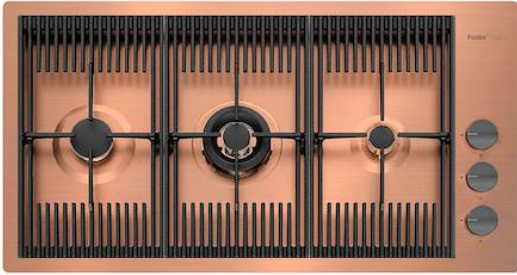

Gas hobs

Code: 7680 008



DETAILS

Coloring Copper

Edge/Installation Type Flush-mount | Top-mount

Finish PVD

Material AISI 304 stainless steel

Texture Brushed in line

Supply 220 - 240 V; 50/60 Hz

Dimensions 870x476 mm

Base size 90cm

Heating element three burners

Built-in hole [View technical data sheet](#)

Grids [Cast iron grids and enamelled burner covers](#)

Width [87 cm](#)

Total power [7.750 W](#)

Auxiliary [1.000 W](#)

Semirapid [1.750 W](#)

Dual [5.000 W](#)

Safety [Safety valve with quick-acting thermocouple](#)

Ignition [Electric ignition under knob](#)

Gas type [Tested for installation with natural gas, LPG nozzle set included.](#)

Type [Gas Hob](#)

FEATURES

Copper [The Copper finish is obtained by treating steel with a physical process called PVD \(Physical Vacuum Deposition\) which deposits particles of noble metals on the surface. The result is a unique and refined aesthetic effect, and an improvement of the mechanical properties of the steel which is more resistant to impact and scratches.](#)

Aeo burners [The AEO burners guarantee up to 25% energy saving compared to standard burners. All models are designed with The Dual burner with 2 independent crowns, controlled by a single knob, delivers from 1 to 5KW, a power that can only be found in professional models.](#)

Cast iron grids

Cast-iron is the ideal material for an hob grid, this due to the manifold properties characterising it: high heat capacity that improves cooking performance; high weight and stability that improve safety; sturdiness that preserves the hob's original aspect over time; easy cleaning.

Safe cooking

All Foster cooker hobs are equipped with safety valves. They shut off the gas supply very quickly if the flame accidentally goes out.

Special burners

Many Foster hobs are equipped with special burners, with two or three rings of fire that greatly increase the power delivered and the heated surface. In the DUAL models the two fire crowns also have independent ignition, making these burners perfect for both intensive and delicate cooking.

Ultra-flat hob

Design meets functionality in the the ultra-flat models. Elegant grids that form a generously sized overall surface.

Under-knob ignition

The utmost freedom of movement with electronic under-knob ignition, a common feature of all models that allows a one-hand ignition of the burner.

TECHNICAL DATA

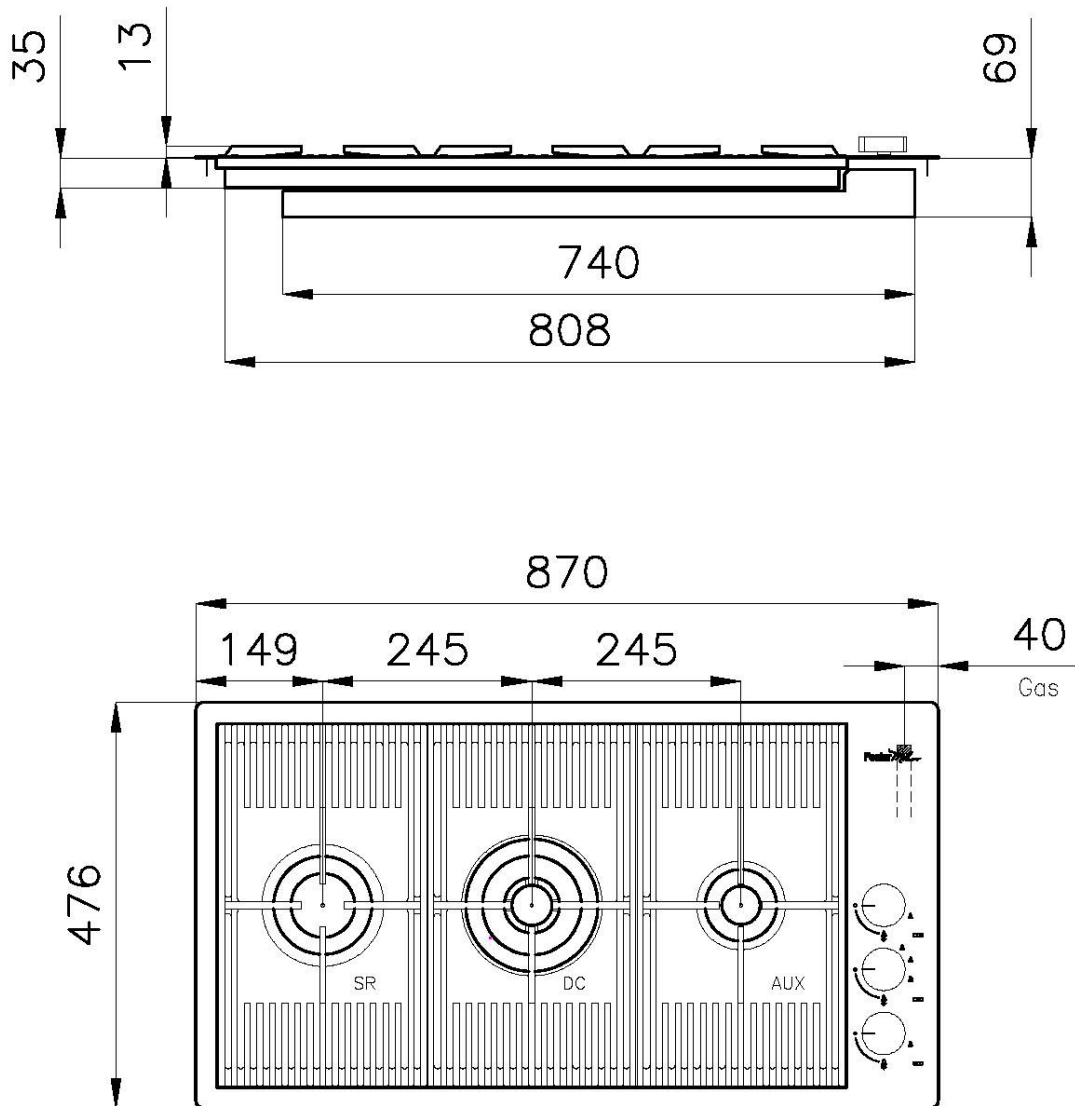

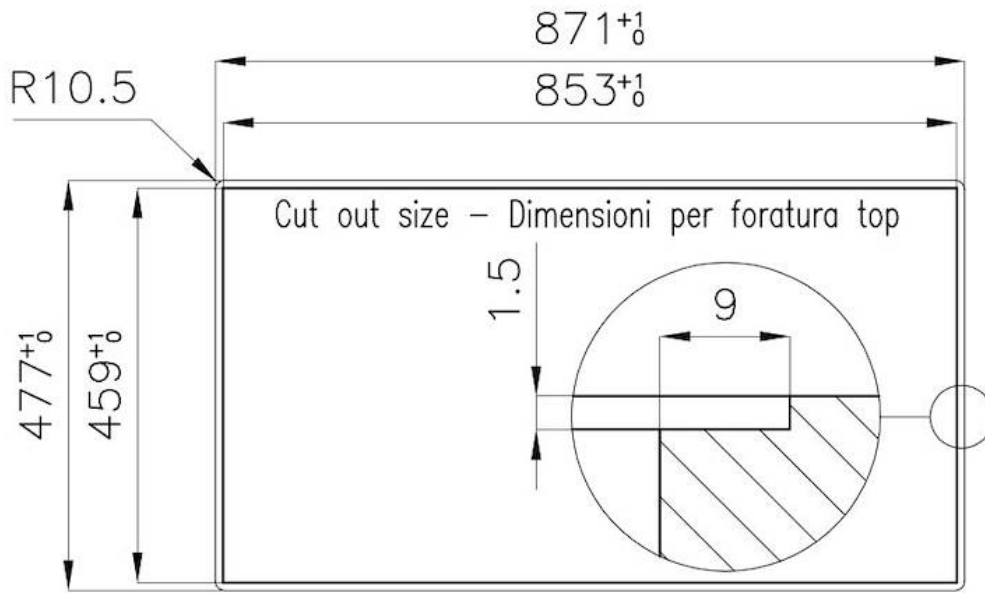

FT

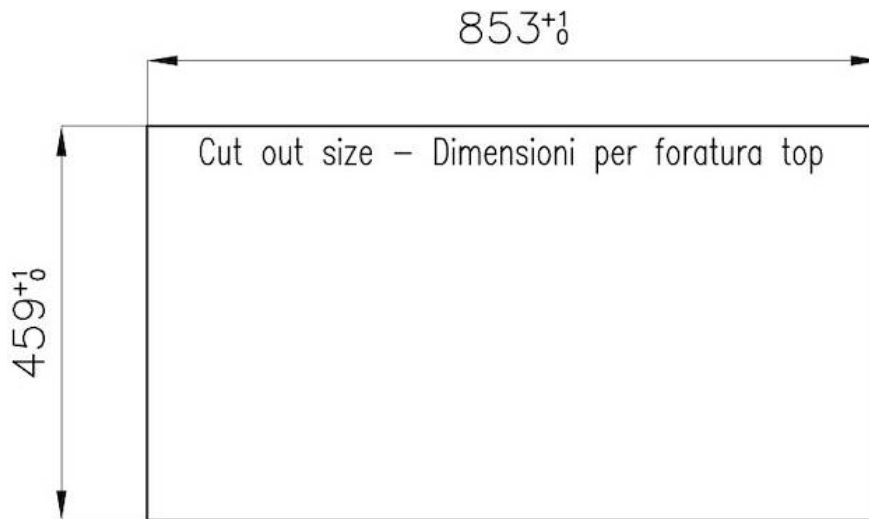

FTS

OPTIONAL ACCESSORIES



Cast iron wok support
9601 727

RECOMMENDED PAIRINGS



Sink Milanello Copper workstation
1034 058



Sink Milanello Copper Workstation
1034 858