

## Cooker hob Foster Milano PVD Copper



Gas hobs

Code: 7639 008



### DETAILS

Type	Gas Hob
Material	AISI 304 stainless steel
Texture	Brushed in line
Finish	PVD
Coloring	Copper
Edge/Installation Type	Flush-mount   Top-mount
Base size	120 cm
Dimensions	1154 x 560 mm
Width	115 cm

Cut out	Check technical data sheet
Heating element	six burners
Supply	220 - 240 V; 50/60 Hz
Total power	15.900 W
Auxiliary	1.000 W
Semirapid	2 x 1.750 W
Rapid	3.000 W
Dual	2 x 4.200 W
Power settings	9 power settings per zone
Ignition	Electric ignition under knob
Gas type	Tested for installation with natural gas, LPG nozzle set included.
Safety	Safety valve with quick-acting thermocouple
Grids	Cast iron grids and enamelled burner covers

## EQUIPMENT

2 x Cast iron Wok support 9601  
727

---

## FEATURES

### 56 cm deep

56 cm deep. An increased dimension synonymous with great functionality, which distinguishes the Foster Milano series.

---

### Aeo burners

The AEO burners guarantee up to 25% energy saving compared to standard burners. All models are designed with The Dual burner with 2 independent crowns, controlled by a single knob, delivers from 1 to 5KW, a power that can only be found in professional models.

---

### Copper

The Copper finish is obtained by treating steel with a physical process called PVD (Physical Vacuum Deposition) which deposits particles of noble metals on the surface. The result is a unique and refined aesthetic effect, and an improvement of the mechanical properties of the steel which is more resistant to impact and scratches.

---

### Safe cooking

All Foster cooker hobs are equipped with safety valves. They shut off the gas supply very quickly if the flame accidentally goes out.

---

### Special burners

Many Foster hobs are equipped with special burners, with two or three rings of fire that greatly increase the power delivered and the heated surface. In the DUAL models the two fire crowns also have independent ignition, making these burners perfect for both intensive and delicate cooking.

---

### Ultra-flat hob

Design meets functionality in the the ultra-flat models. Elegant grids that form a generously sized overall surface.

---

### Under-knob ignition

The utmost freedom of movement with electronic under-knob ignition, a common feature of all models that allows a one-hand ignition of the burner.

---

### XXL grids

The weighty enamelled cast iron grid has extraordinary dimensions, 33x25 cm, with a working surface up to 50% bigger compared to a standard cooker hob. Now you can use all the burners at the same time even with large cookware.

---

## TECHNICAL DATA

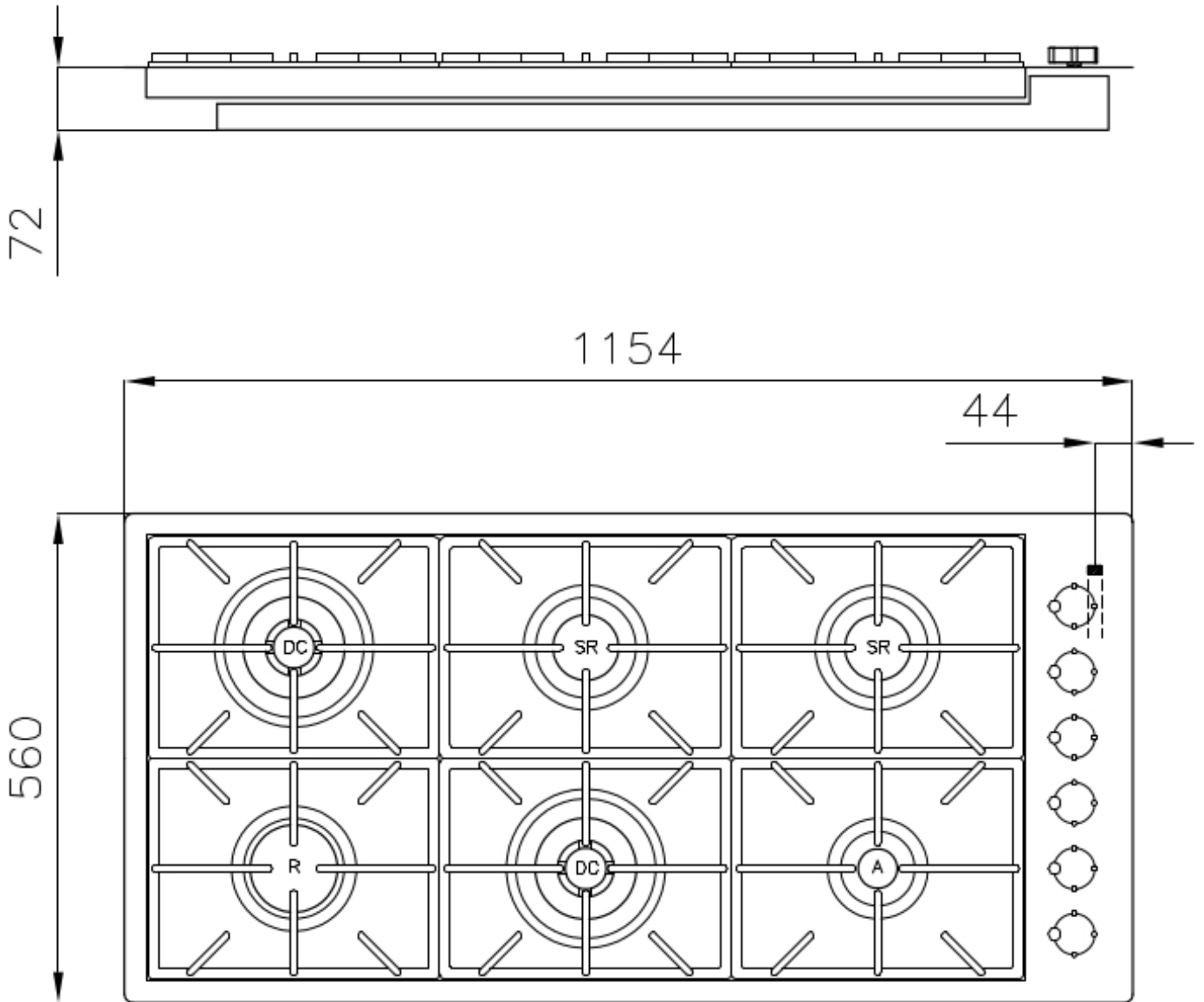

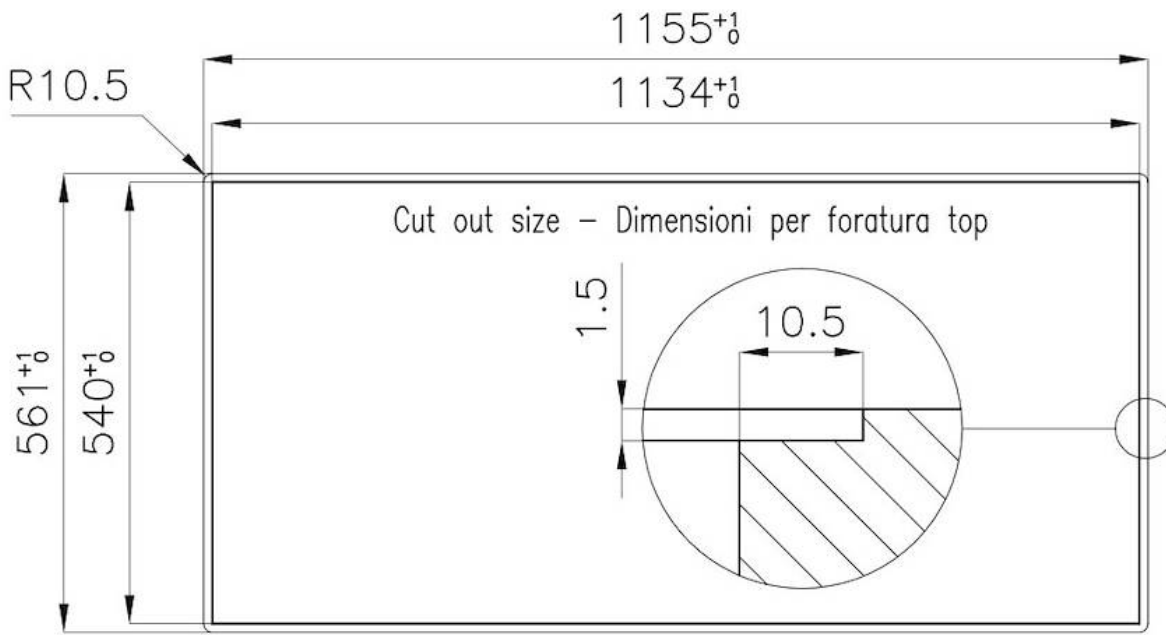

**FT**

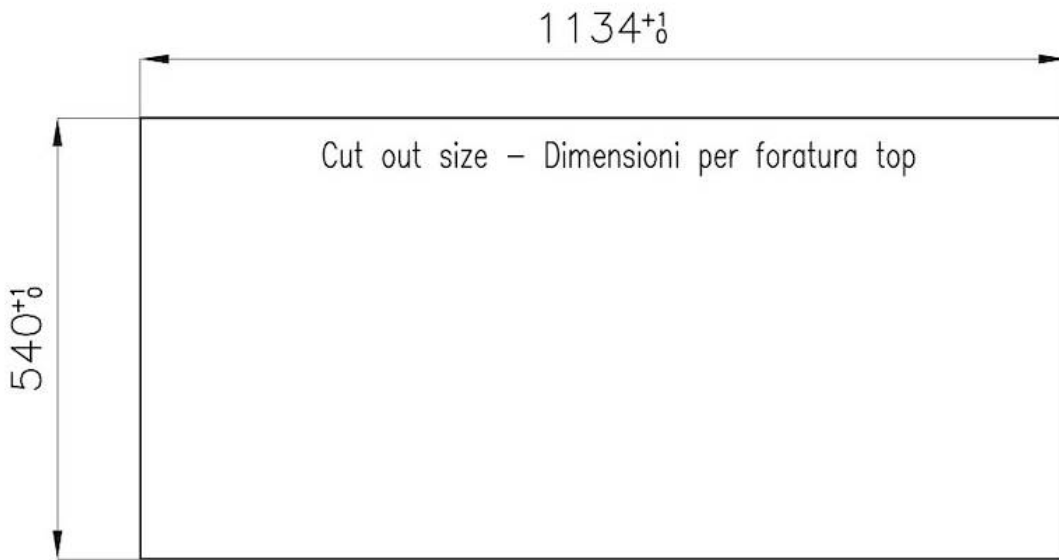

**FTS**

## GALLERY



## EQUIPMENT



**Cast iron wok support**  
9601 727

## RECOMMENDED PAIRINGS



**Sink Milanello Copper workstation**  
1034 058