

Cooker hob Foster Milano PVD Copper



Gas hobs

Code: 7638 008



DETAILS

Type	Gas Hob
Material	AISI 304 stainless steel
Texture	Brushed in line
Finish	PVD
Coloring	Copper
Edge/Installation Type	Flush-mount Top-mount
Base size	120 cm
Dimensions	1056 x 560 mm
Width	105 cm

Cut out	Check technical data sheet
Heating element	Five burners
Supply	220 - 240 V; 50/60 Hz
Total power	10.950 W
Auxiliary	2 x 1.000 W
Semirapid	1.750 W
Rapid	3.000 W
Dual	4.200 W
Power settings	9 power settings per zone
Ignition	Electric ignition under knob
Gas type	Tested for installation with natural gas, LPG nozzle set included.
Safety	Safety valve with quick-acting thermocouple
Grids	Cast iron grids and enamelled burner covers

EQUIPMENT

1 x Cast iron wok support 9601
727

FEATURES

56 cm deep	56 cm deep. An increased dimension synonymous with great functionality, which distinguishes the Foster Milano series.
Aeo burners	The AEO burners guarantee up to 25% energy saving compared to standard burners. All models are designed with The Dual burner with 2 independent crowns, controlled by a single knob, delivers from 1 to 5KW, a power that can only be found in professional models.
Cast iron grids	Cast-iron is the ideal material for an hob grid, this due to the manifold properties characterising it: high heat capacity that improves cooking performance; high weight and stability that improve safety; sturdiness that preserves the hob's original aspect over time; easy cleaning.
Copper	The Copper finish is obtained by treating steel with a physical process called PVD (Physical Vacuum Deposition) which deposits particles of noble metals on the surface. The result is a unique and refined aesthetic effect, and an improvement of the mechanical properties of the steel which is more resistant to impact and scratches.
Special burners	Many Foster hobs are equipped with special burners, with two or three rings of fire that greatly increase the power delivered and the heated surface. In the DUAL models the two fire crowns also have independent ignition, making these burners perfect for both intensive and delicate cooking.
Under-knob ignition	The utmost freedom of movement with electronic under-knob ignition, a common feature of all models that allows a one-hand ignition of the burner.
XXL grids	The weighty enamelled cast iron grid has extraordinary dimensions, 33x25 cm, with a working surface up to 50% bigger compared to a standard cooker hob. Now you can use all the burners at the same time even with large cookware.

TECHNICAL DATA

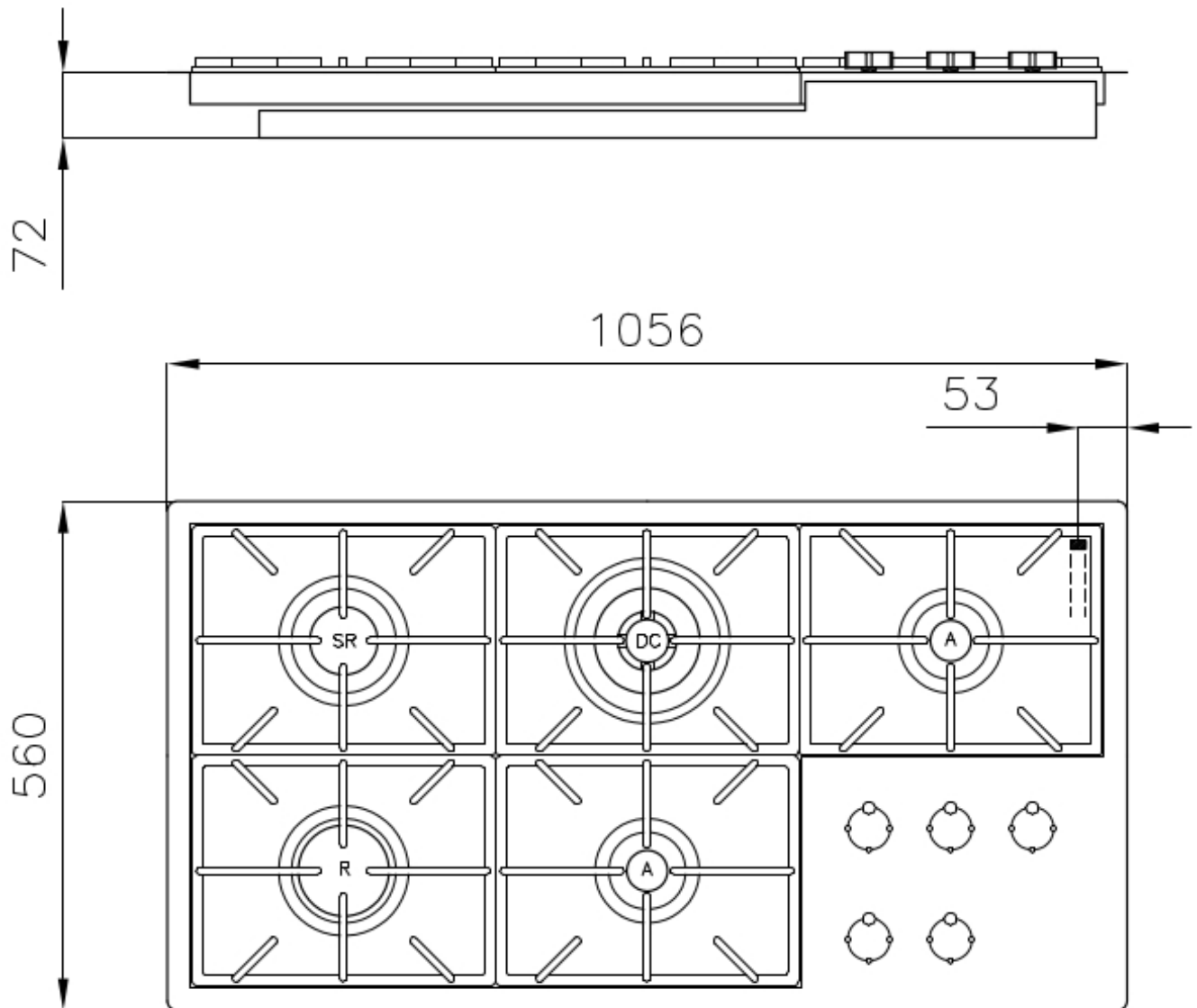

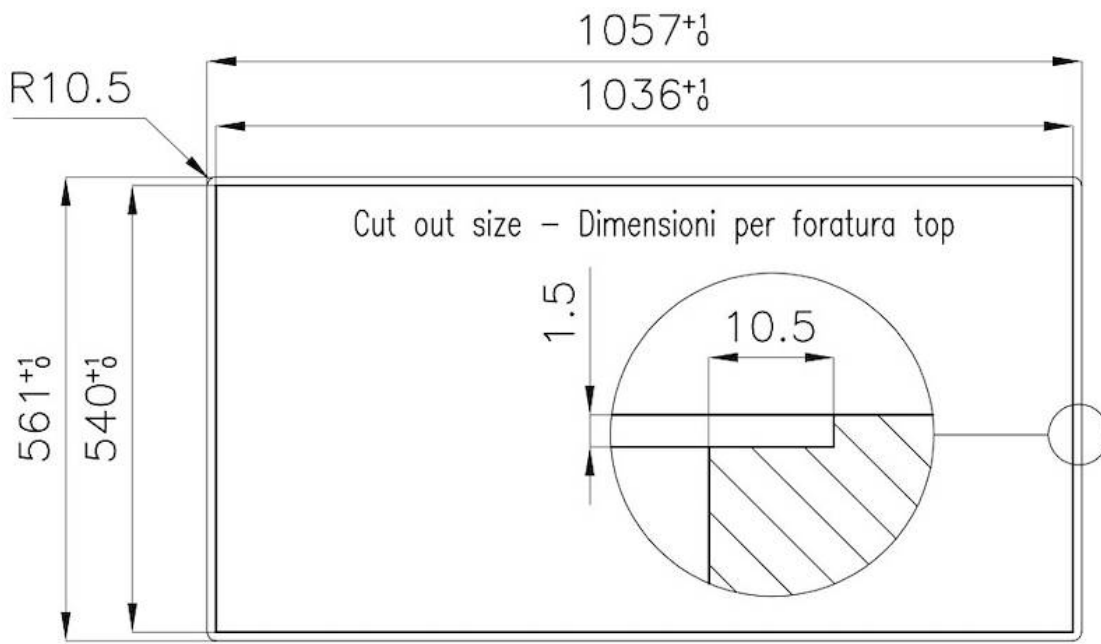

FT

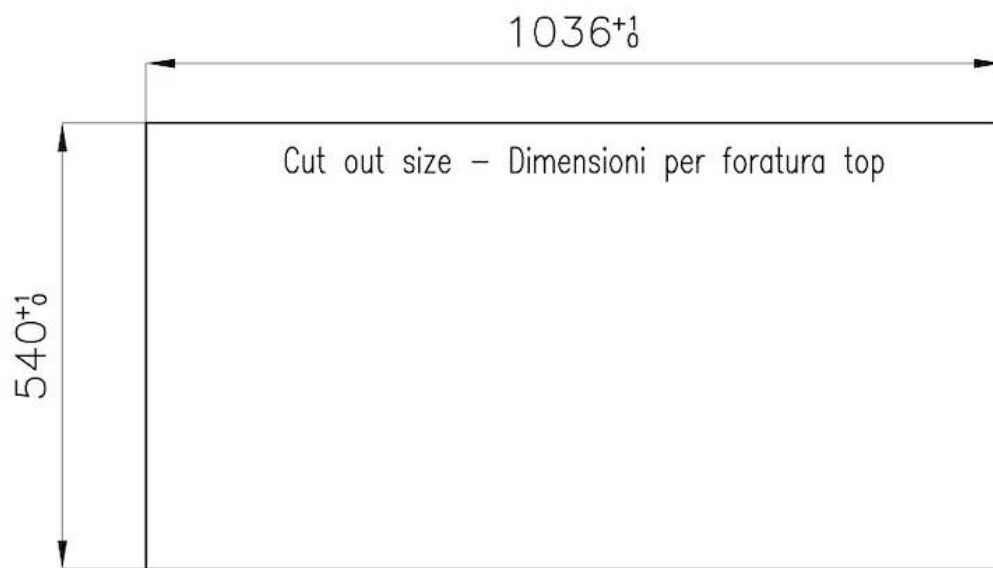

FTS

GALLERY



EQUIPMENT



Cast iron wok support
9601 727

RECOMMENDED PAIRINGS



Sink Milanello Copper workstation
1034 058