

Oven KS

Ovens and Coordinated Products

Code: 7122 055



COOKING PROGRAMS

Bottom Cooking + Fan	Programme that ensures limited energy consumption, ideal for heating foodstuffs or for foodstuffs that require delicate, gradual cooking.
Double grill + Fan	For the final stages of cooking of foods such as roasts and poultry, to give the surfaces the right browning.
Intensive cooking	The upper and lower heating elements and the fan ensure rapid, uniform cooking. ideal for cooking pizzas, roasts, lasagne and savoury pies.
traditional cooking	The ideal function for all traditional recipes, including bread, cakes and roasts.
Lower-level cooking	Suitable for heating foodstuffs.
Double Grill	Heat is generated by the upper grill only: ideal for toasting, cooking au gratin and browning foodstuffs and also suitable for meat, fish and pasta.
Lower-level cooking + grill	To complete static cooking and to cook au gratin simultaneously.
Ventilated grill	The combined action of the fan and grill produces rapid and thorough cooking of thick foodstuffs.

DETAILS

Material Stainless steel + glass

Texture Satin Finish ANTI-TOUCH

Supply 220-240 V 50/60 Hz

Energy class A

Dimensions 60x60 cm

Standard fittings 1 baking tray and 1 dripping pan with EasyClean XXL enamel - 1 stainless steel grill

Cooking chamber finish Easy Clean enamel

Number of door glasses 2 glasses

Programming End of cooking timer

Type of cooling Tangential ventilation

Safety Grill resistance protection

Oven type Multifunction oven

Type of commands Retractable knobs push-push

Volume 70Lt

FEATURES

A energy class	A range totally in Class A ++, A + and A. An important result that proves the high quality, aimed at optimizing performance and savings.
XL capacity	The cooking chamber has a volume of over 70 liters, higher than that of standard ovens.
Full glass door	The inside of the oven door constitutes a single smooth glass surface making it practical for cleaning purposes.
Easy clean enamelling	The Easy-Clean enamelling makes the internal oven surfaces and accessories non-adhesive, while the limited porosity ensures durability and easy cleaning.
Tangential fan	A special ventilation creates a flow of air between the cooking chamber and framework, thereby reducing the temperature of the external surfaces. As consequence, the oven does not expose furniture to temperature shock.
Anti-touch finish	The steel parts of the door, thanks to the special protection, are perfectly smooth and protected from fingerprints, while maintaining the elegance of the satin finish.

TECHNICAL DATA

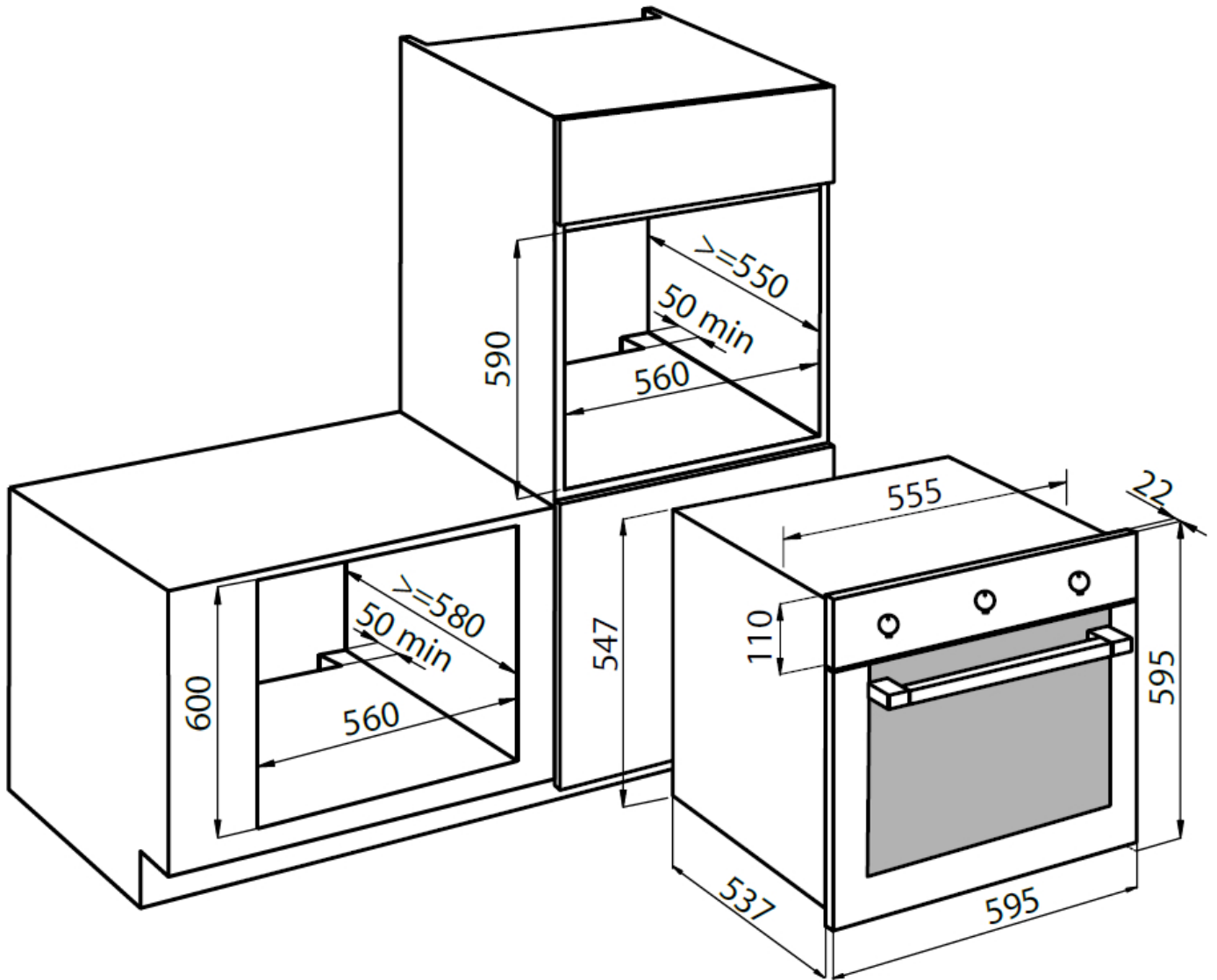

RECOMMENDED PAIRINGS



Plate-warmer module

7104 000