

Oven FL

Ovens and Coordinated Products

Code: 7107 042

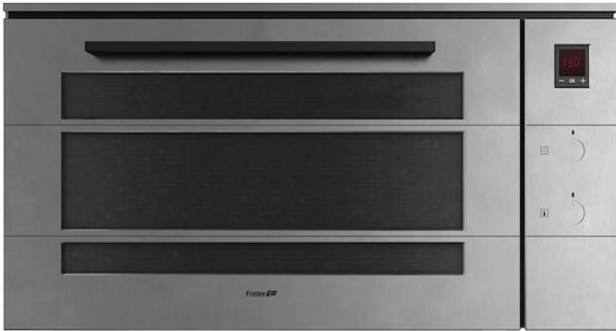

COOKING PROGRAMS

Lower-level cooking	Suitable for heating foodstuffs.
traditional cooking	The ideal function for all traditional recipes, including bread, cakes and roasts.
Intensive cooking	The upper and lower heating elements and the fan ensure rapid, uniform cooking. ideal for cooking pizzas, roasts, lasagne and savoury pies.
Ventilated cooking	The combination of ventilation and circular heating elements allows for cooking different types of foodstuffs together, without mixing aromas and flavours.
Central grill	Heat is generated by the upper grill only: ideal for toasting, cooking au gratin and browning foodstuffs and also suitable for meat, fish and pasta.
Double Grill	Heat is generated by the upper grill only: ideal for toasting, cooking au gratin and browning foodstuffs and also suitable for meat, fish and pasta.
Lower-level cooking + grill	To complete static cooking and to cook au gratin simultaneously.
Double grill + Fan	For the final stages of cooking of foods such as roasts and poultry, to give the surfaces the right browning.

DETAILS

Coloring Black Mirror

Material AISI 304 stainless steel

Texture Vintage ANTI-TOUCH

Supply 220-240 V 50/60 Hz

Energy class A

Dimensions 90 x 48 cm

Standard fittings Deep pan + Stainless steel grill

Cooking chamber finish Easy Clean enamel

Guides 2 Telescopic guides

Grill Collapsible Maxi Grill with safety protection

Lighting Double offset halogen light

Number of door glasses 3 glasses

Programming Electronic start-end cooking program

Type of cooling Tangential ventilation

Safety Grill resistance protection

Oven type Multifunction oven

Type of commands Retractable knobs push-push

Volume 91 Lt

FEATURES

A energy class A range totally in Class A ++, A + and A. An important result that proves the high quality, aimed at optimizing performance and savings.

XXL capacity The cooking chamber has a volume of over 70 liters, much greater than that of standard ovens.

telescopic guides The guides on which run pans and grids favor a better distribution of space and make it easier to extract the dishes.

Triple glass The door is equipped with a multiple glass door. This device ensures low temperatures of external surfaces and lower heat loss.

Stop-sol glass finish The special screening and mirroring treatment of external glass gives the oven an elegant and modern aesthetic. The oven remains dark when not in use, once the illumination is switched on the inside is perfectly visible.

Full glass door The inside of the oven door constitutes a single smooth glass surface making it practical for cleaning purposes.

Easy clean enamelling The Easy-Clean enamelling makes the internal oven surfaces and accessories non-adhesive, while the limited porosity ensures durability and easy cleaning.

Tangential fan

A special ventilation creates a flow of air between the cooking chamber and framework, thereby reducing the temperature of the external surfaces. As consequence, the oven does not expose furniture to temperature shock.

Anti-touch finish

The steel parts of the door, thanks to the special protection, are perfectly smooth and protected from fingerprints, while maintaining the elegance of the satin finish.

TECHNICAL DATA

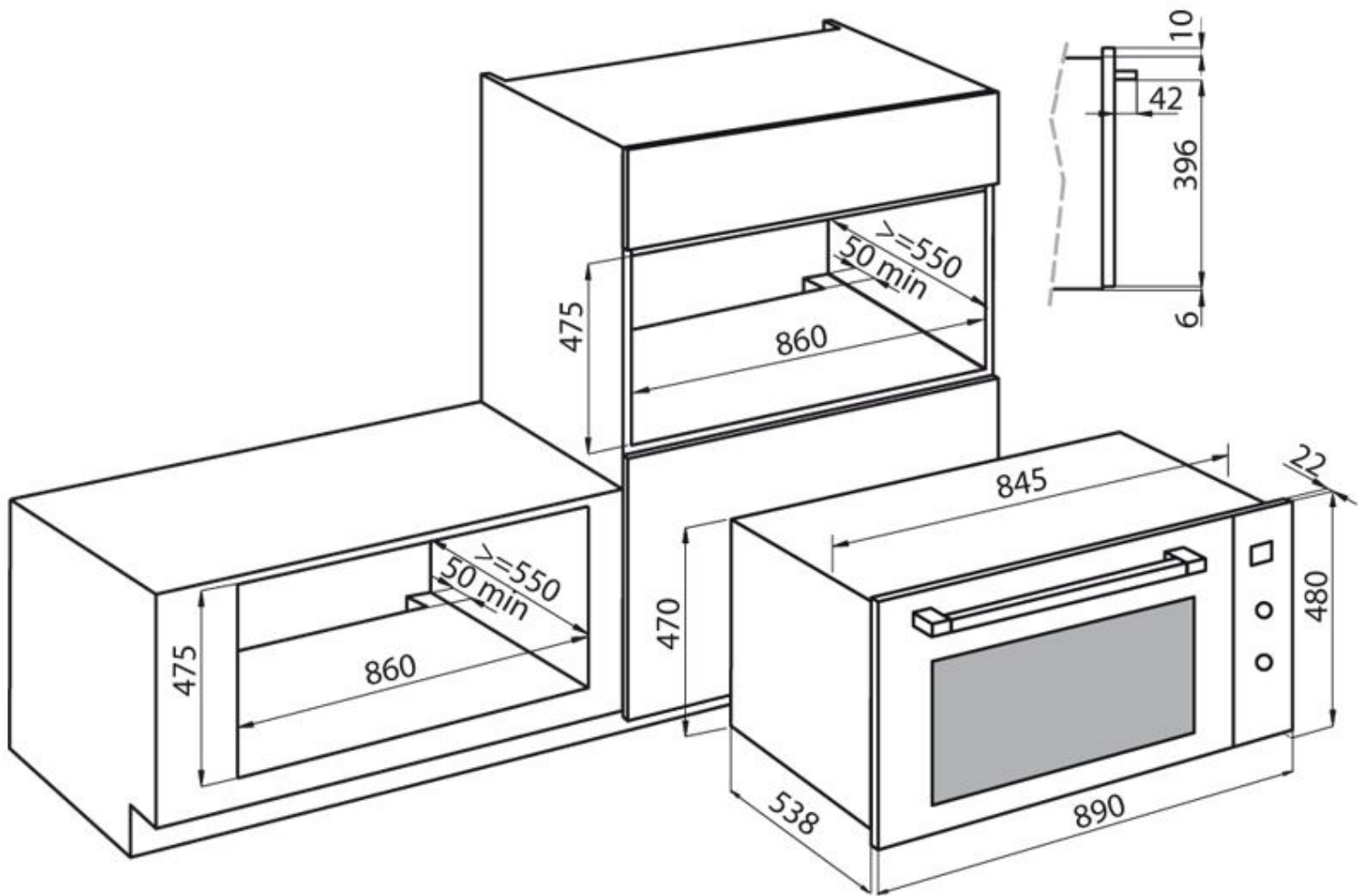

GALLERY

