

Oven FL 7106 653

Ovens and Coordinated Products

Code: 7106 653



COOKING PROGRAMS

Upper-level cooking Suitable for cooking particularly delicate foodstuffs and for keeping them warm after cooking.

Lower-level cooking Suitable for heating foodstuffs.

traditional cooking The ideal function for all traditional recipes, including bread, cakes and roasts.

Ventilated cooking The combination of ventilation and circular heating elements allows for cooking different types of foodstuffs together, without mixing aromas and flavours.

ECO Ventilated Cooking Program with low energy consumption, ideal for heating and for foods that need gentle and progressive cooking.

Central grill Heat is generated by the upper grill only: ideal for toasting, cooking au gratin and browning foodstuffs and also suitable for meat, fish and pasta.

Double Grill Heat is generated by the upper grill only: ideal for toasting, cooking au gratin and browning foodstuffs and also suitable for meat, fish and pasta.

Auto Roast In the automatic meat cooking mode (AUTO ROAST), the top heating element works in conjunction with the grill element and the round heating element. This mode is used for cooking all types of meat.

Ventilated grill	The combined action of the fan and grill produces rapid and thorough cooking of thick foodstuffs.
Ventilated Cooking + Bottom Cooking	The harmony of two cooking types make an excellent program for the creation of an amazing pizza, of quiches or stuffed desserts.
Bottom Cooking + Fan	Programme that ensures limited energy consumption, ideal for heating foodstuffs or for foodstuffs that require delicate, gradual cooking.
Keep warm	Ideal to keep at the right temperature before serving.
Thawing	It allows you to defrost foods in a third of the time through the uniform distribution of air at room temperature.
Plate warmer function	It is used when you want to preheat the service (plates, cups) to keep the food warm longer. By selecting the symbol, specify the temperature and the start and end time of heating.
Fast pre-heating function	This function turns on the heating elements and a flow of hot air raises the temperature to 200°C within a very short time.

DETAILS

Coloring	Black Mirror
Material	Glass
Supply	220-240V 50-60Hz
Energy class	A+
Dimensions	60x60 cm

Standard fittings Low baking tray (2x) - Deep drip tray - Glass drip tray - Stainless steel grid.

Cooking chamber finish Easy Clean enamel

Guides 3 Full extension telescopic guides

Lighting Double offset halogen light

Number of door glasses 3 glasses

Programming Self Cooking Plus electronic programming

Type of cooling Tangential ventilation - dynamic cooling Plus

Oven type Multifunction oven

Type of commands Touch Control - Display TFT

Volume 72Lt

FEATURES

A+ energy class A range totally in Class A ++, A + and A. An important result that proves the high quality, aimed at optimizing performance and savings.

XXL capacity The cooking chamber has a volume of over 70 liters, much greater than that of standard ovens.

self cooking plus Rich and complete recipes can be recalled intuitively by the practical touch controls and widely customizable with your creations.

Heat probe

It records the temperature at the core of the product at all times. Once the cooking temperature has been set, the oven signals when the core of the food has reached it, and deactivates the heating elements.

Fast pre-heating

This function turns on the heating elements and a flow of hot air raises the temperature to 200°C within a very short time.

Fully extractable telescopic guides

The guides on which run pans and grids favor a better distribution of space and make it easier to extract the dishes. Even more comfortable and safe thanks to complete extraction from the cooking chamber.

Triple glass

The door is equipped with a multiple glass door. This device ensures low temperatures of external surfaces and lower heat loss.

Full glass door

The inside of the oven door constitutes a single smooth glass surface making it practical for cleaning purposes.

Easy clean enamelling

The Easy-Clean enamelling makes the internal oven surfaces and accessories non-adhesive, while the limited porosity ensures durability and easy cleaning.

Tangential fan

A special ventilation creates a flow of air between the cooking chamber and framework, thereby reducing the temperature of the external surfaces. As consequence, the oven does not expose furniture to temperature shock.

Multi-level cooking

The special ventilation makes the temperature uniform and avoids the mixing of smells, thus allowing to cook different kinds of food at the same time.

Soft closing door

The door's hinges automatically slow down in the final part of their movement, to achieve a delicate and silent closing.

TECHNICAL DATA

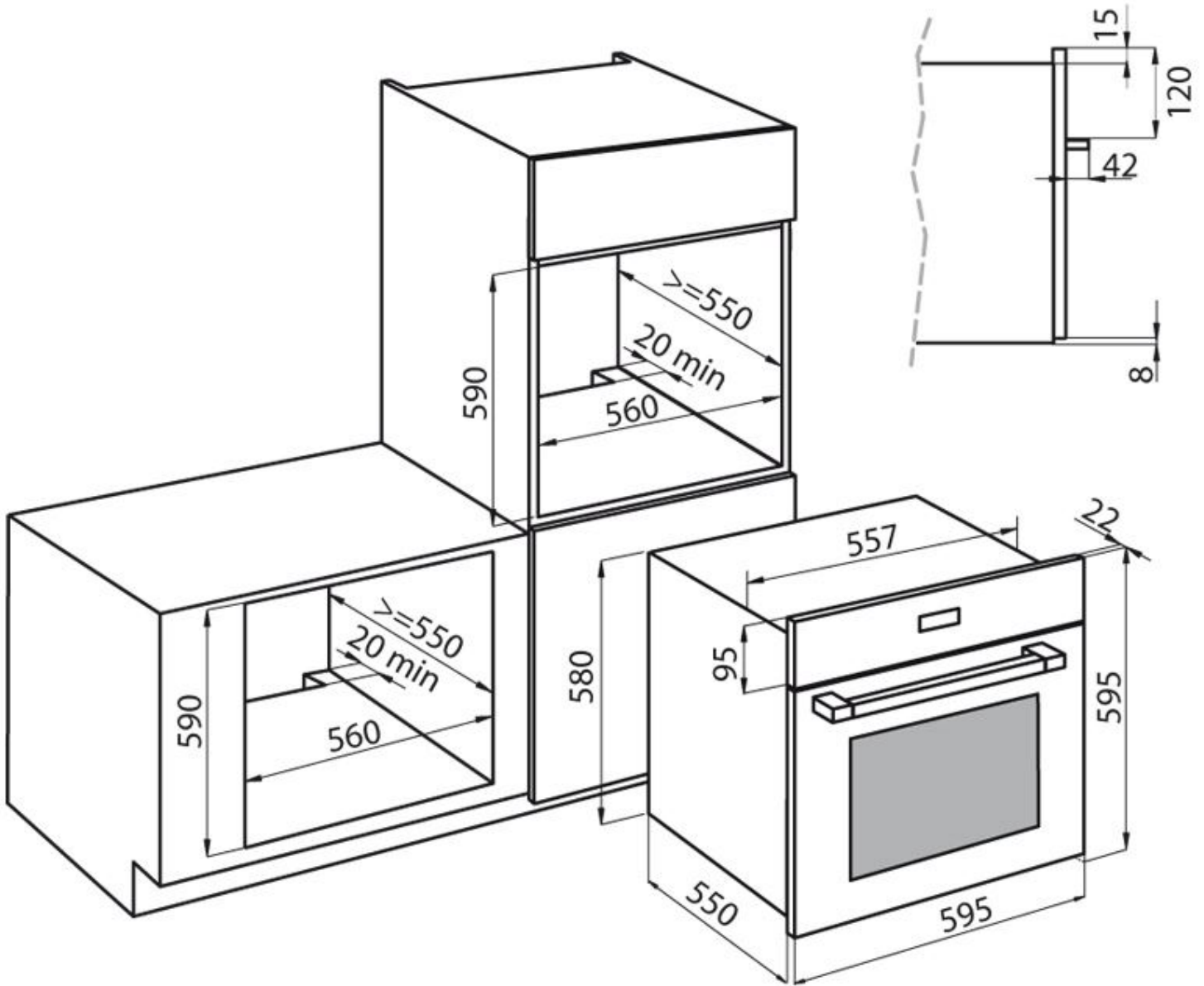

GALLERY

