

Oven FL

Ovens and Coordinated Products

Code: 7104 020



COOKING PROGRAMS

Ventilated cooking	The combination of ventilation and circular heating elements allows for cooking different types of foodstuffs together, without mixing aromas and flavours.
Grill	To quickly gratin the surface of the food.
Double grill + Fan	For the final stages of cooking of foods such as roasts and poultry, to give the surfaces the right browning.
Microwave cooking	Ideal for cooking or rapidly heating vegetables, rice, fish, meat and liquids. different power levels are available.
Microwave + grill	A combined cooking method that is ideal for lasagne, potatoes, roasts and pies.
microwave + fan	The movement of air generated by the fan ensures better homogeneity of micro cooking.

DETAILS

Coloring	Black Mirror
----------	--------------

Material	Glass
Supply	220-240 V 50/60 Hz
Dimensions	60x46 cm
Standard fittings	1 Integrated turntable Ø 32 cm - 1 Stainless steel grill - 1 Glass drip pan
Cooking chamber finish	Easy Clean enamel
Number of door glasses	2 glasses
Turntable	Ø 32 cm can be deactivated
Power absorbed by the microwave	1000 W (6 livelli potenza) + Grill 1000 W
Programming	Electronic self-cooking programming
Type of cooling	Tangential ventilation
Safety	Display Lock
Timer	adjustable 0-90 min.
Oven type	Combi-microwave oven
Type of commands	Touch Control

Volume

32Lt

FEATURES

Self cooking

An intuitive and advanced programming system that allows to recall a wide set of preset recipes and to memorize exclusive ones.

Stop-sol glass finish

The special screening and mirroring treatment of external glass gives the oven an elegant and modern aesthetic. The oven remains dark when not in use, once the illumination is switched on the inside is perfectly visible.

Full glass door

The inside of the oven door constitutes a single smooth glass surface making it practical for cleaning purposes.

Automatic thawing

It is possible to defrost not only setting the time but also alternatively the type and weight of the food.

Safe cooking

All Foster cooker hobs are equipped with safety valves. They shut off the gas supply very quickly if the flame accidentally goes out.

Tangential fan

A special ventilation creates a flow of air between the cooking chamber and framework, thereby reducing the temperature of the external surfaces. As consequence, the oven does not expose furniture to temperature shock.

Anti-touch finish

The steel parts of the door, thanks to the special protection, are perfectly smooth and protected from fingerprints, while maintaining the elegance of the satin finish.

TECHNICAL DATA

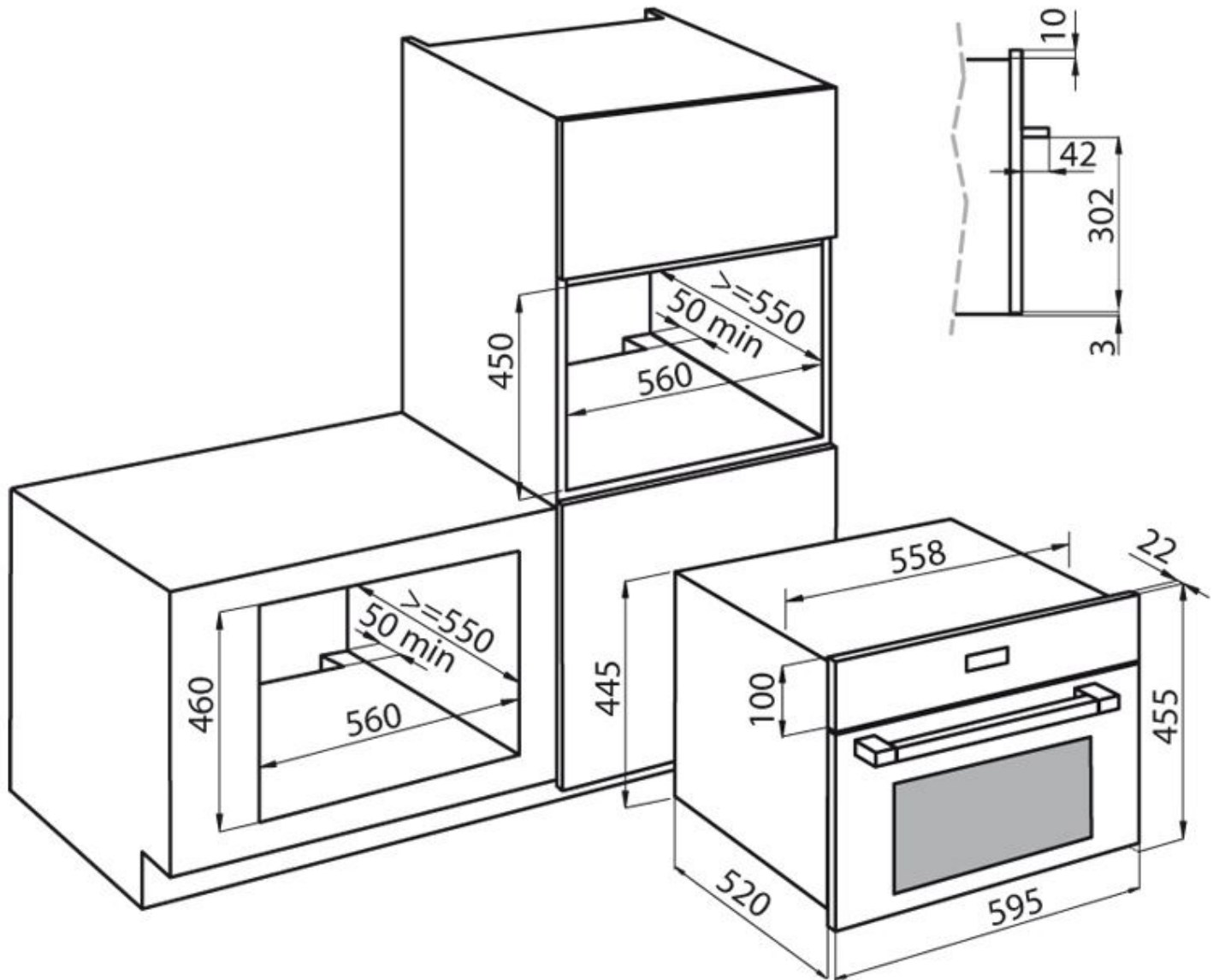

GALLERY

