



## Hood Florence

Hoods

Code: 2538 121 120

120 cm

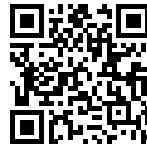

### DETAILS

Material Stainless steel

---

Texture Brushed in line

---

Chimney height

---

Energy class A

---

Product details Telescopic chimney

---

Grease filters commercial style baffle filters

---

Operation Suction hood (filtering mode with optional carbon filters)

---

Air exhaust hole  $\varnothing$  120/150 mm

---

Lighting LED lighting (4.000 kelvin)

---

Air flow rate

---

Motor power

---

Hood type Wall-mounted suction hood

---

Type of commands Electronic pushbutton

---

Suction speed 4 operating speeds

---

Notes: Fume exhaust ducts must have an internal diameter not lower than 120 mm

---

## FEATURES

**Auto delayed shutdown** All the models with electronic interface can be programmed to turn off the suction at a postponed moment, so as to prolong the aeration of the room even after the cooking has been completed.

---

**high performance** Foster hoods motors have a high suction capacity. Their refined design hides a powerful appliance with professional features.

---

**Led lighting** Particular attention to energy saving with LED lighting systems. They assure a 10 times lower consumption and a 10 times longer duration. Our LED lights are designed to create an adequate comfort and safety in the cooking area.

---

**Steel filters** Where the filter is in plain sight, the aluminium filtering element is covered in stainless steel. This solution improves the look and increases the durability of the product.

---

## TECHNICAL DATA

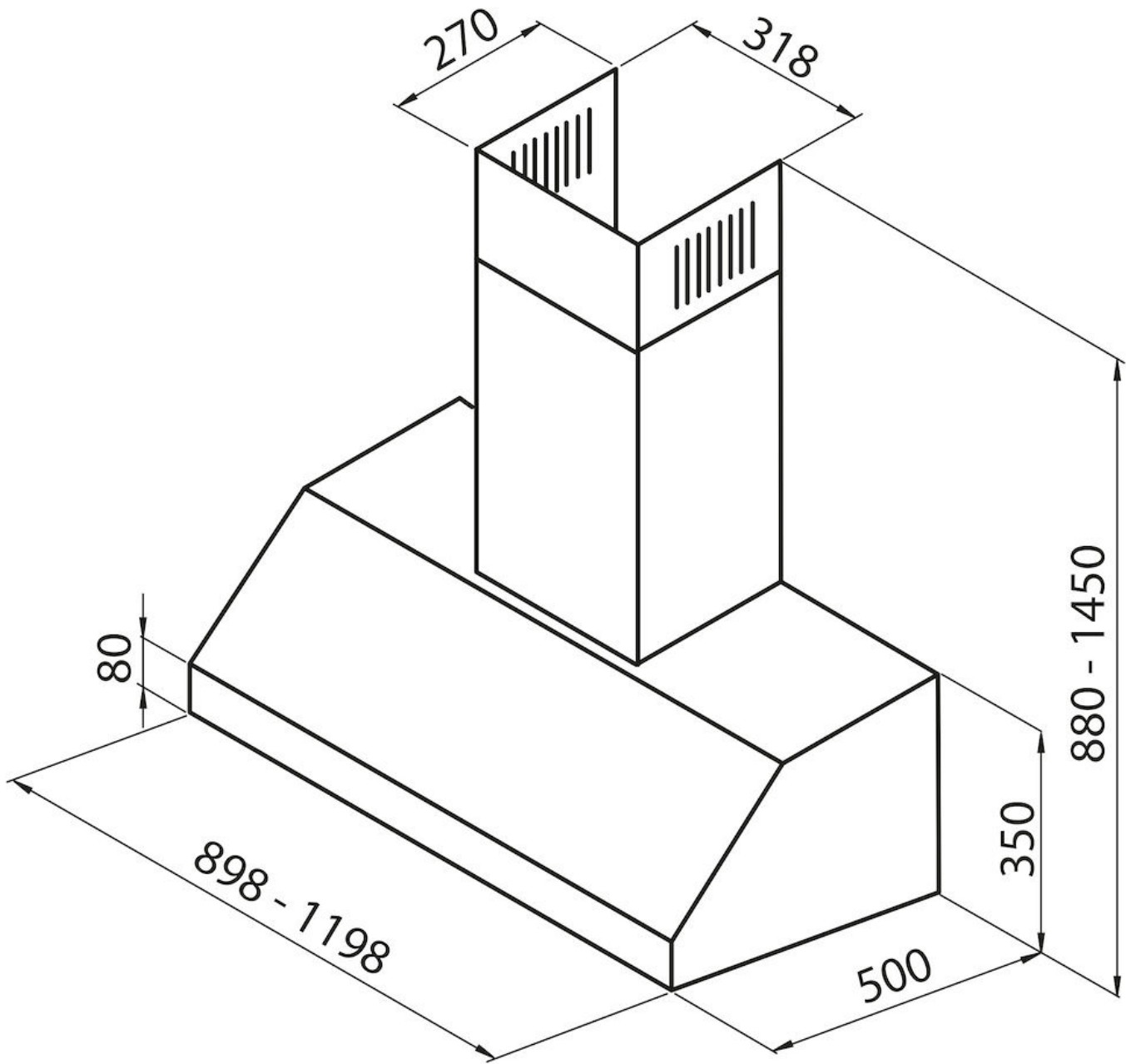

## GALLERY



## OPTIONAL ACCESSORIES



Carbon filter