



Hood Florence 2538091_2538121

Hoods

Code: 2538 091_2538 121

Code: 2538 091 90 cm

Code: 2538 121 120 cm



DETAILS

Chimney height

Energy class A

Product details Telescopic chimney

Grease filters commercial style baffle filters

Operation Suction hood (filtering mode with optional carbon filters)

Air exhaust hole ø 120/150 mm

Lighting LED lighting (4.000 kelvin)

Material/Finish satin finish steel

Air flow rate

Motor power

Hood type Wall-mounted suction hood

Type of commands Electronic pushbutton

Suction speed 4 operating speeds

FEATURES

Auto delayed shutdown All the models with electronic interface can be programmed to turn off the suction at a postponed moment, so as to prolong the aeration of the room even after the cooking has been completed.

high performance Foster hoods motors have a high suction capacity. Their refined design hides a powerful appliance with professional features.

Led lighting Particular attention to energy saving with LED lighting systems. They assure a 10 times lower consumption and a 10 times longer duration. Our LED lights are designed to create an adequate comfort and safety in the cooking area.

Steel filters Where the filter is in plain sight, the aluminium filtering element is covered in stainless steel. This solution improves the look and increases the durability of the product.

TECHNICAL DATA

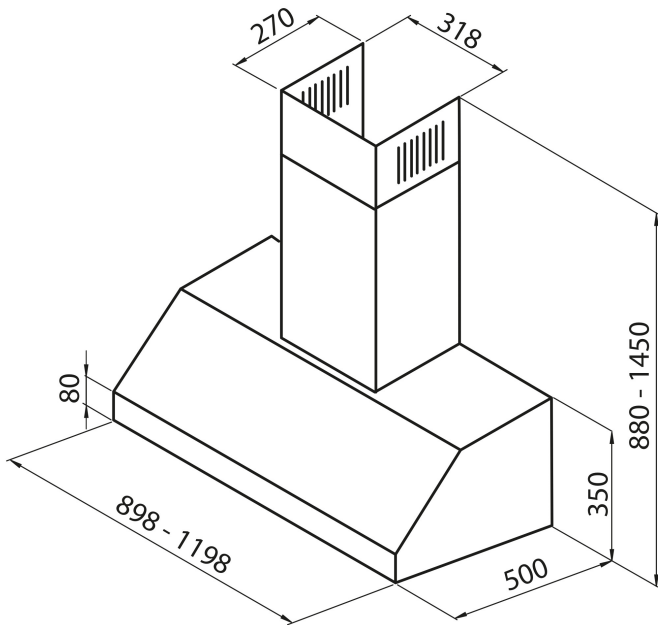

GALLERY



OPTIONAL ACCESSORIES



Carbon filter 9700 292