



Hood Modular System

Hoods

Code: 2518 001

Code: 2518 001 Control

Code: 2519 001 Subordinate



DETAILS

Coloring White

Material Stainless steel

Texture Satin Finish - glass

Energy class D

Ceiling – false ceiling distance min 220 mm / max 310 mm

Full description Modular - modular ceiling suction system

Grease filters 1 grease filtre

Operation Suction hood (filtering modality not available)

Cut out 340x340 mm

Air exhaust hole \varnothing 120 mm

Lighting Low consumption LED lighting

Notes: Fume exhaust ducts must have an internal diameter not lower than 120 mm

Notes: The height of the hood from the hob suggests the use of at least two suction modules, for adequate suction.

Air flow rate 400mc/h

Motor power 140W

Hood type Ceiling suction hood

Type of commands Remote control

Suction speed 4 operating speeds

FEATURES

Auto delayed shutdown All the models with electronic interface can be programmed to turn off the suction at a postponed moment, so as to prolong the aeration of the room even after the cooking has been completed.

Led lighting Particular attention to energy saving with LED lighting systems. They assure a 10 times lower consumption and a 10 times longer duration. Our LED lights are designed to create an adequate comfort and safety in the cooking area.

Perimetric aspiration The perimeter suction is a feature common to many Foster hoods. The filters are hidden by steel- or crystal plates and the suction occurs along their perimeter. This has aesthetic advantages but also functional ones: the cleaning is easier, the suction power and noise-level are improved. The depression which occurs in the perimeter area facilitates in fact the suction of the particles composing the fumes.

Remote control

The ceiling suction systems and the Maya hoods are equipped with a remote control to easily activate all their functions from any position.

TECHNICAL DATA

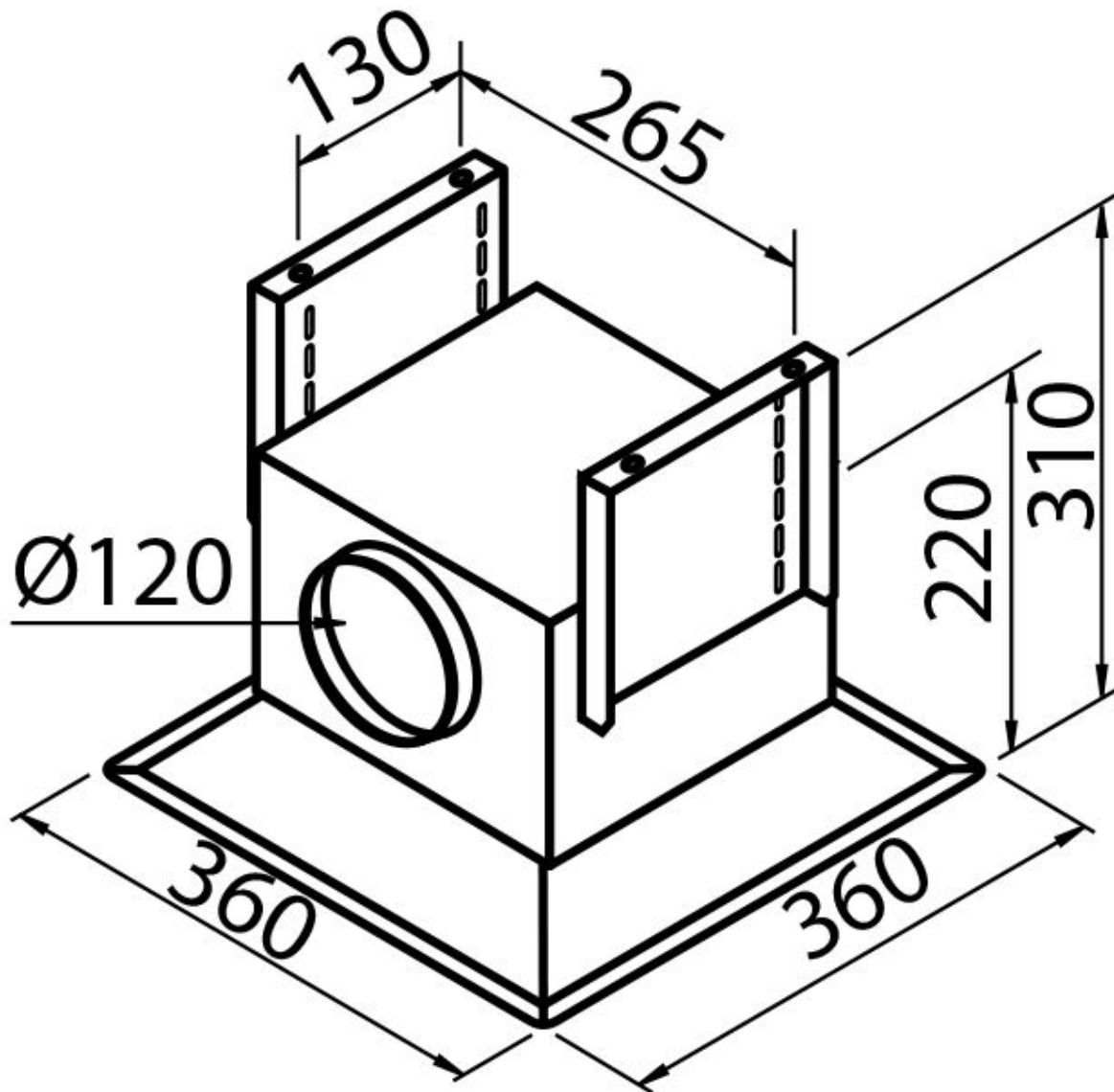

GALLERY

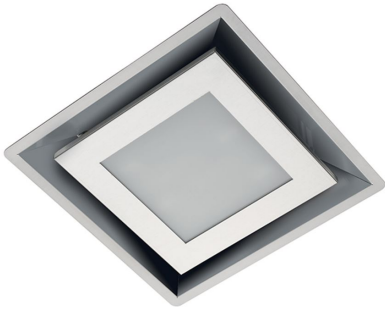

OPTIONAL ACCESSORIES

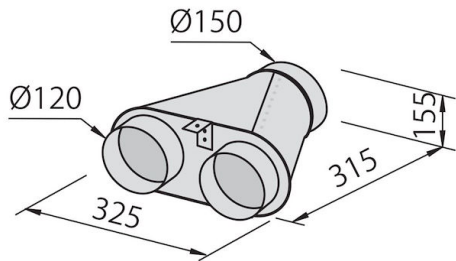

Collector for 2 pipes

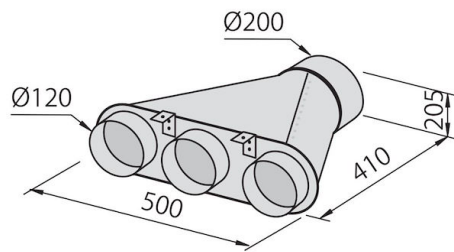

Collector for 3 pipes

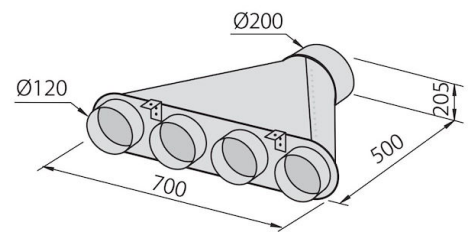

Collector for 4 pipes



Flexible silencing canalization



Modular light