



Refrigerator

60cm total no frost combined refrigerator

Refrigerators

Code: 2040 010



DETAILS

Type	Built-in combined refrigerator
Control type	LED interface with touch controls
Lighting	Internal backlighting with LED panel
Door	Reversible - Standard hinges on the right
Total gross capacity	237 lt
Refrigerator net capacity	170 lt
Freezer net Capacity	67 lt
Supply	220 - 240 V; 50/60 Hz
Annual energy consumption	235 kWh

Energy class	E
Climate class	SN, N, ST, T (+10 °C / +43 °C)
Noise level	37 dB - Class C
Dimensions	540 x 550 x 1776 mm
Accessories supplied	Egg holder, ice holder, reclining bottle holder
Functions	<ul style="list-style-type: none">- Fast cool- Fast freeze- Holidays mode- Cool zone- Auto clean

FEATURES

LED PANEL	The large, highly efficient backlit LED panel ensures uniform brightness on every level of the refrigerator, ensuring perfect visibility of all foods.
COOL ZONE	The special Cool Zone drawer is an ideal storage area for fresh food, be it meat or fruit and vegetables, significantly increasing their period of preservation. The ventilation of the refrigerator compartment is channelled directly into the drawer, thus maintaining a temperature lower than that one in the rest of refrigerator.
TOTAL NO FROST	The No-Frost technology removes moisture from the freezer with a forced ventilation system in controlled temperature and humidity conditions. No more ice that reduces the usable volume, glues packings one to the other and compromises performance.

TECHNICAL DATA

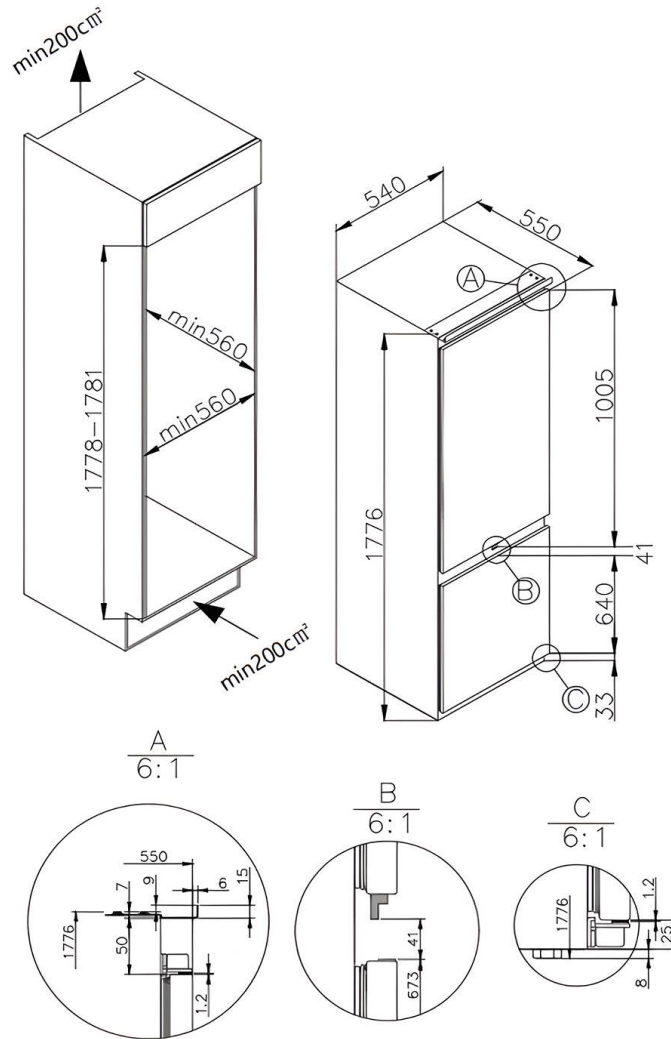

GALLERY

