

Refrigerator 2038 000

Refrigerators

Code: 2038 000



DETAILS

Supply 220-230V - 50Hz

Alarms Double alarm: door open / temperature

Total gross capacity 305Lt

Refrigerator net capacity 301Lt

Hinges Slide

Climate class SN/T (tropical +10°C/+43°C)

Energy class A++

Annual energy consumption 113kWh

Dimensions 540x1772x545 mm

Lighting	LED
Door	Reversible - std hinges on the right
Noise level	37dB(A)
Control type	Electronic control with LED display
Fridge type	single-door built-in refrigerator
Type	Built-in single-door refrigerator

FEATURES

Advanced fast freeze	These functions are available on models with digital programming; they respectively allow the freezing and quick cooling of large quantities of food.
Fresh zone	The special Fresh Zone drawer is an ideal storage area for fresh food, be it meat or fruit and vegetables, significantly increasing their period of preservation. The ventilation of the refrigerator compartment is channelled directly into the drawer, thus maintaining a temperature lower than that one in the rest of refrigerator.
Humidity control	The spacious drawer in the bottom area is specifically thought for fruit and vegetables. It preserves the necessary humidity so that the fresh produce can maintain their original amount of water, weight and fragrance.
Personal system	This system constantly checks the way the appliance is used, with the goal to maintain the optimal temperature regardless of how often the door is opened. Indeed, when the door is opened, the temperature suddenly rises, which causes a thermal shock to the food which can reduce its shelf-life. The system will foresee the moments of more intense use, and will anticipate the necessary cycles to keep the temperature as constant as possible.
Ventilated refrigerator	The ventilation of the refrigerator area allows a perfect homogeneity of cooling and improves the preservation of food, ensuring that it remains longer fresh. The system also avoids the formation of odours and condensation on the walls, without changing the internal humidity which prevents the food, especially the fresh ones, from drying in a short time.

TECHNICAL DATA

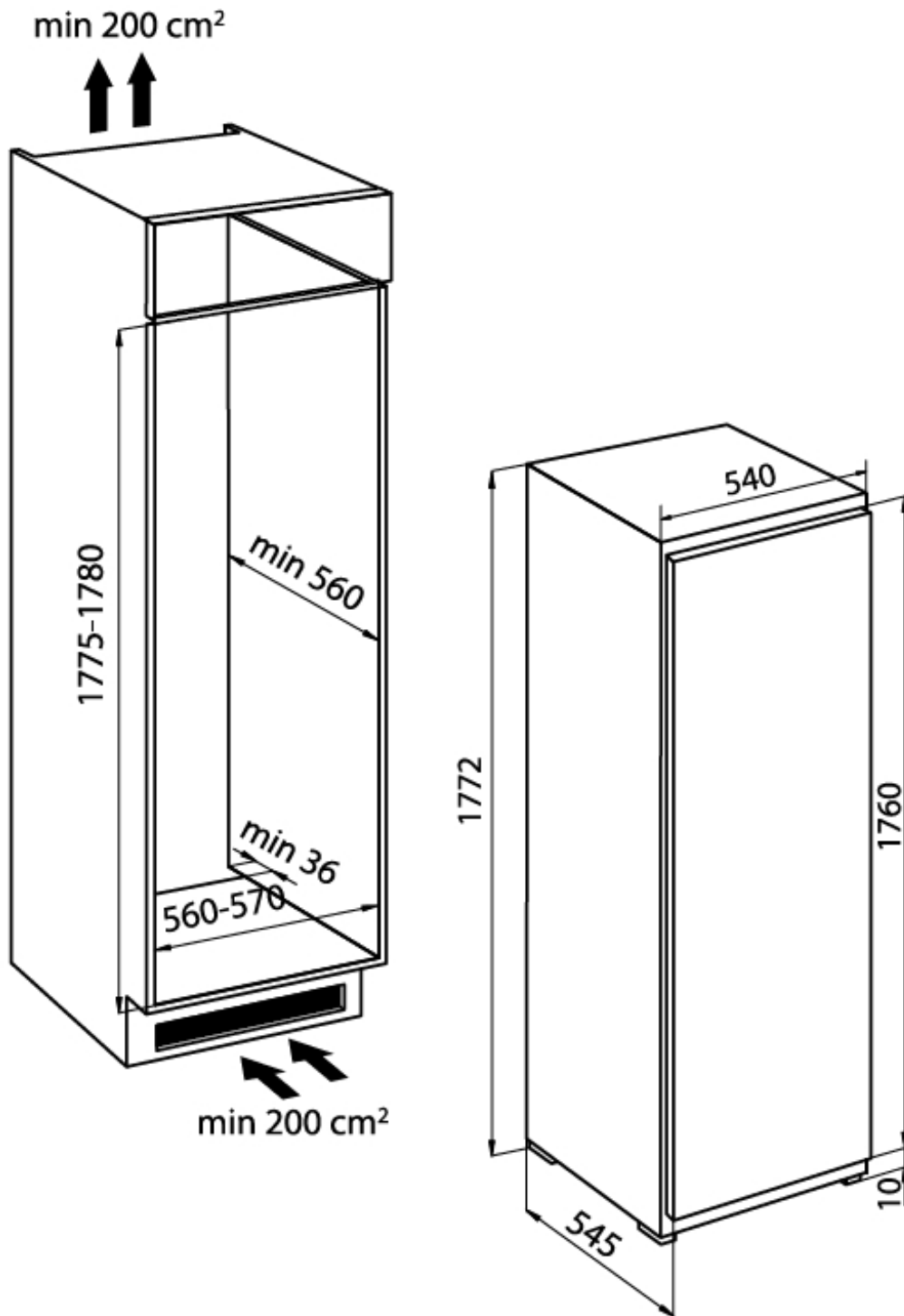

OPTIONAL ACCESSORIES



Kit for side by side installation
2038 039